

***EZ-* LATCH TO STEEL BOARD FENCE INSTALLATION INSTRUCTIONS**

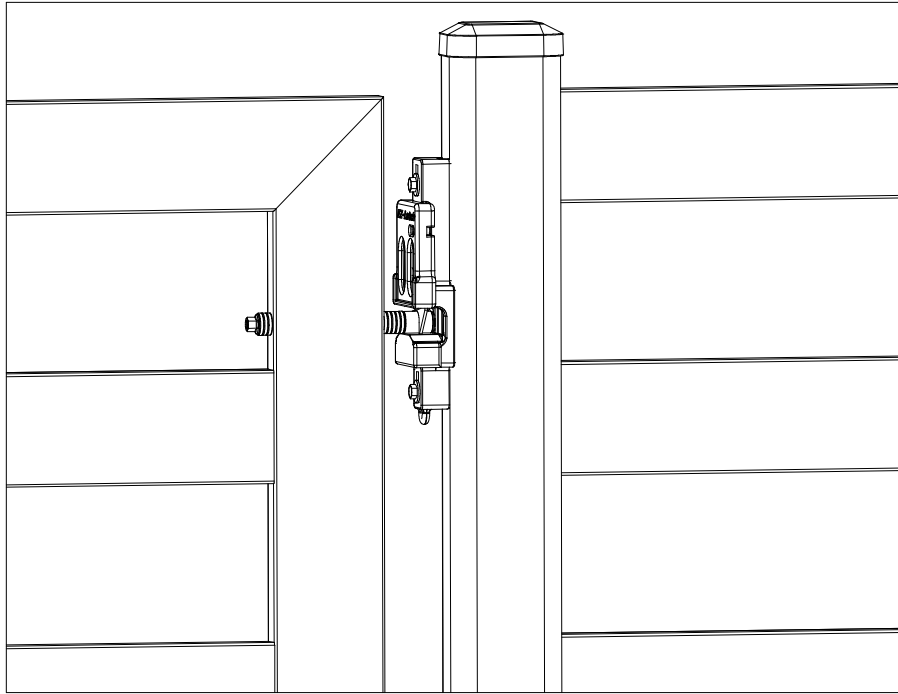

TOOLS REQUIRED:

3/8" chuck drill motor

1/2" Drill Bit (note: a step drill is preferred that starts small and steps up to 1/2". This makes the drilling easier). if this is not available we suggest multiple drills.

Adjustable wrench

5/16" hex key wrench

Marking pen.

DOC. 98-001858-00

EZ- LATCH MOUNT TO STEEL BOARD FENCE

Step #1

Place enough washers on the latch pin as shown in Figure 1 to allow the end of the pin to clear the latch post by 1/2" or slightly more and slide the pin into the face of the gate.

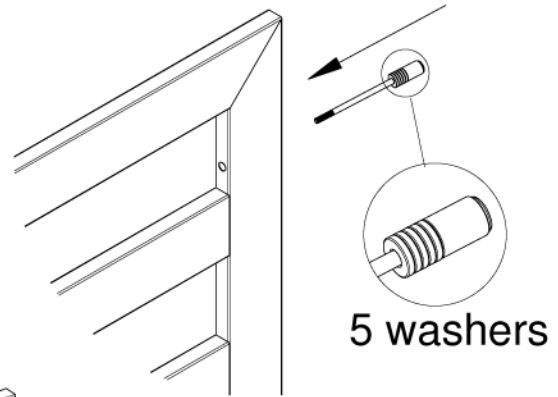

Figure 1

Step #2

Slide the spacer onto the pin and into the gate as shown in Figure 2. Be careful not to pull the pin and allow the spacer to drop into the gate.

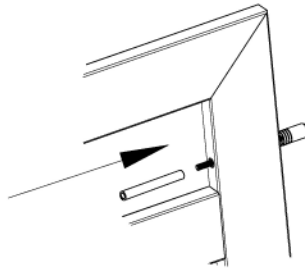

Figure 2

Step #3

Place the remaining washers and nut on to the pin as shown in Figure 3 and tighten to 20 ft. lbs by using a 5/16" hex key in the end of the pin to hold it from rotation while tightening the nut.

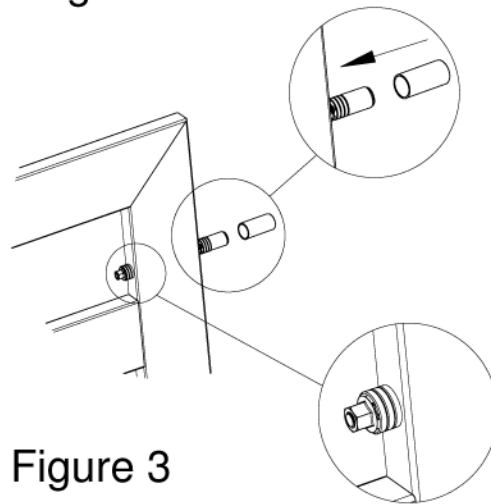

Figure 3

Step #4 Leveling and aligning the gate (must be done before mounting the latch)

When the gate is placed on its gate post the post top will be seated firmly in the upper bearing inside the gate. Assure this by lifting and wiggling from the end of the gate until seating is confirmed. Once seated there should be very little play in the gate when lifting the end.

Place a level on the gate's top rail. Check level. If leveling adjustments needed, have a helper lift the weight off the end of the gate to allow easy rotation of the lower bearing. Remove the two lower bearing retainer screws. Rotate the bearing using a 5/16" hex key in the holes provided to level the gate.

Release the gate and check the level until the optimum bearing adjustment position is found.

Note: the two holes used to rotate the bearing are directly below the screw holes in the bearing. Line the bearing screw holes with the holes in the gate bottom and replace the screws. Do not over tighten. Also, look down the fence line and judge the final position of the gate relative to the fence top rail. They should be in line.

DOC. 98-0011858-00

EZ- LATCH MOUNT TO STEEL BOARD FENCE

CAUTION: Gate must be leveled before mounting to the latch. See page 2 or 3 Step #4.

Step 1: Swing the gate with the mounted latch pin into position with the latch post and position the latch on the post as shown in Figure 1. Position the latch so the latch pin is in the latch box slot as shown and mark the latch post at the center of the top mounting slot of the latch box for drilling.

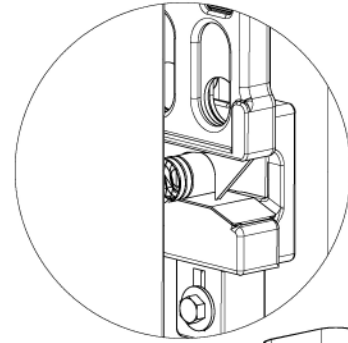

Figure 1

Step 2: Position the top threaded hole of the mounting plate on the top mark. Mark the center of the bottom mount plate hole. Drill two 1/2" diameter holes at the marked spots.

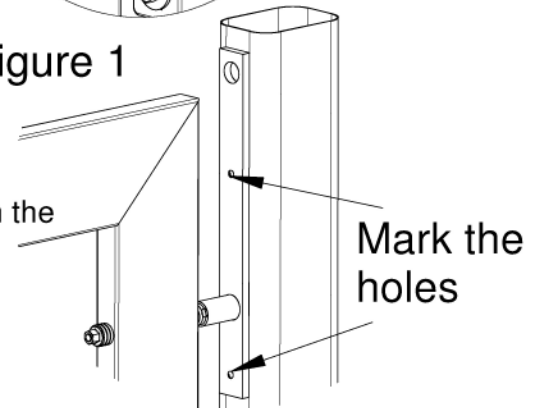

Figure 2

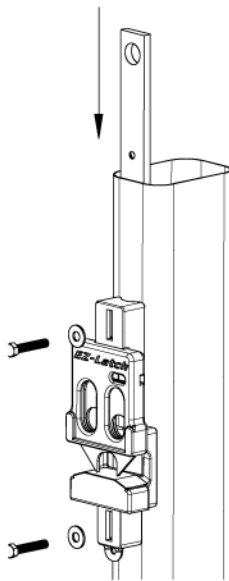

Figure 3

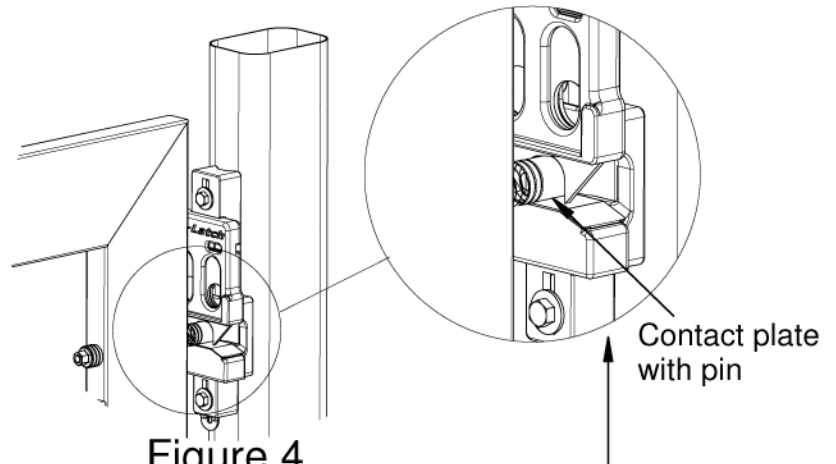

Figure 4

Step 3: Slide the latch plate into the post as shown in Figure 3 using the large hole in the top of the plate for holding. As a safety measure you may tie a string through the hole to allow retrieval of the plate should you accidentally drop it. Secure the latch to the post using the two screws and washers. With the screws snugged into position, swing the gate into the latch. Push the latch up until the bottom plate of the latch contacts the latch pin as shown in Figure 4 and tighten the screws.

DOC. 98-001858-00